

Features

- Capacity from 600kg to 30ton
- Easy operation and rugged construction
- Large bright red LED(1.2 inch) , display with wide view angle
- Integrative load cell, overloading safety up to 400%
- Weight units kilogram (kg), pound (lb)
- Tare; Zero; function
- Adjustable gravity value
- 1/3,000 division
- Auto-zero tracking; Power-saving mode
- One charge can be lasting up to 150 hours
- Low power indication and auto power off
- Remote control distance over 20m

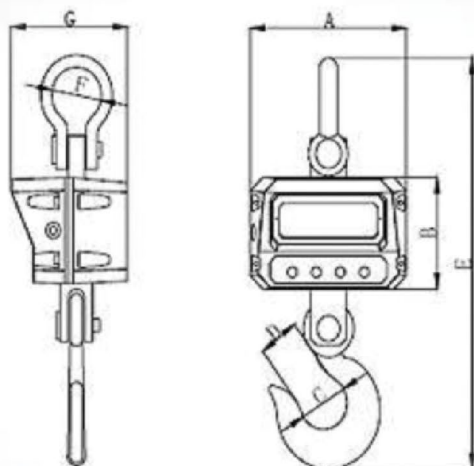

Dimension



Model No.	A	B	C	D	E	F	G	DIVISION
GS-C-0.6T	260	170	50	35	580	68	194	0.2/0.1
GS-C-1T	260	170	50	36	580	68	194	0.5/0.2
GS-C-2T	260	170	50	36	580	68	194	1/0.5
GS-C-3T	260	170	50	36	580	68	194	1/0.5
GS-C-5T	260	170	63	45	670	74	194	2/1
GS-C-10T	260	170	76	61	770	92	204	5/2
GS-C-20T	260	170	107	86	900	127	214	10/5
GS-C-30T	260	170	127	101.6	1100	146	214	10/5